

D-Lock Mini Coupler Models HD015 & HD025 Installation and Operation manual

SERIAL NUMBER: _____

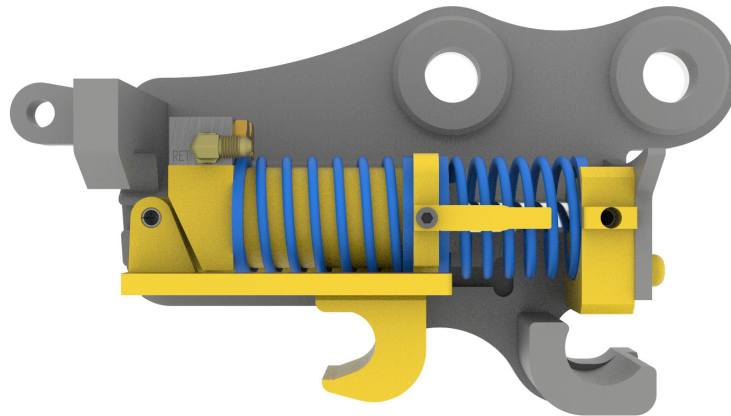

The D-Lock Mini Coupler (Fully Automatic with Dual Pin Locking)

NZ Patent Nos. 579987 & 572477; Australian Patent Nos. 2009320503, 2014100573, 2010301197, 2012101853 & 2016201504; US Patent No. 9,206,582.
NZ Patent Application Nos. 711782; Australian Patent Application Nos. 2015203463 & 2016201504; US Patent Application Nos. 13/127,450 & 14/844,481;
European Patent Application Nos. 09829374.9 & 10820884.4; Canadian Patent Application No. 2,813,185.

Other International Patents pending

Release 1.1, May 2020: File Reference SA467060

IMPORTANT:

Please read and understand this Manual BEFORE Installing and/or operating this coupler.

A copy of this booklet should be kept with the machine at all times.

D-Lock Couplers are compliant with Australian Standard AS4772-2008, Workcover NSW WC01783 position paper, European Standard EN474, ISO13031

P +64 7 574 3000 | **F** +64 7 574 8030 | **E** sales@dohertydirect.net

FREEPHONE AUS 1800 057 021 | 98 Paerangi Place, Tauriko Tauranga 3110, Bay of Plenty, New Zealand

CONTACTS

NEW ZEALAND:

Phone: 07 574 3000

Fax: 07 574 8030

Postal:

PO Box 9339, Greerton
Tauranga, 3142

Physical:

98 Paerangi Place, Tauriko
Tauranga 3110

Support:

Jordan Hignett

Email: nzsupport@dohertydirect.net

Phone: 021 792 790

AUSTRALIA:

Phone: 1800 057 021

Brisbane HQ (QLD):

Postal:

PO Box 701
Annerley, QLD, 4103

Physical:

Unit 2 / 2642 Ipswich Road
Darra, QLD, 4076

Support

Matt Harris

Email: matt@dohertydirect.net

Phone: 0455 411 241

Melbourne Warehouse (VIC, SA, TAS, NSW):

Postal:

PO Box 701
Annerley, QLD, 4103

Physical:

Factory 4, 21-22 National Drive
Hallam, Victoria, 3803

Support

Reuben Cooper

Email: reuben@dohertydirect.net

Phone: 0448 345 726

TABLE OF CONTENTS

TITLE	PAGE
Contacts	2
Pre delivery check	3
Risk assessment	4
Important safety information	6
Product identification & decals	7
Suitability of attachments	10
Product specifications	11
Installation	12
Operation	19
Maintenance	25
Torque settings and port sizes	34
Parts list	35
Troubleshooting	37
Warranty policy	39
Warranty procedure	42
Assessment form	43
Revision log	45

PRE-DELIVERY CHECK

Installation completed by:

Company:	
Name:	
Date:	
Excavator make and model:	
Coupler Serial #	
End username:	
End user phone number:	
End user address:	
End user email address:	

Doherty D-Lock keypad fitted If not please note make and model of type used:	
Lock circuit pressure checked at:	PSI
Unlock circuit pressure checked at:	PSI
Hose routings checked and abrasion free throughout full crowd movement:	
All supplied attachments locked and unlocked from coupler:	
All hydraulic connections, clean, tight and leak free:	
Please specify type and brand of control valve fitted	

This form must be returned to Doherty Engineered upon completion of Installation to validate warranty.

NOTES:

RISK ASSESSMENT

This risk assessment form is supplied as a guide only. It is the responsibility of the owner / operator to ensure that this equipment is operated in a safe manner and complies with all relevant compliance regulations.

Location of risk assessment:	Date:
------------------------------	-------

Typical hazards associated with this equipment	Personnel affected			
	Indicate in table below			
Type	Operator	Site personnel	Service personnel	General public
Changing Attachments				
Is there a copy of the operations manual in the machine cabin?				
Has the operator been correctly trained for use with this particular coupler and verified?				
Is the operator aware they should not operate this machine unless they are satisfied that the coupler is in a safe condition?				
Are all personnel aware that they must not remain near attachments during attachment changes?				
Falling objects				
Are all personnel aware that they must not position themselves under attachments or suspended loads?				
Lifting equipment				
Is the SWL rating of the equipment clearly displayed?				
Does all lifting equipment carry a current SWL certification?				
Warning devices and Decals				
Are all safety and operations decals clearly displayed?				
Does the operator check that the equipment warning devices are operational daily?				
Equipment malfunction				
Is there a checklist of daily, weekly, monthly inspections?				
Is there a record of all service / repair work?				

Other hazards identified:	
Plant & machinery movement Warning devices on plant and equipment Noise Environment	

Assessed by:	Reported to:
Name	Name
Date	Date

RISK ASSESSMENT

Daily prestart check list

Operators Name:	Date:
-----------------	-------

Coupler serial number:	S	M	T	W	T	F	S
Check all attachment pin retainer bolts and nuts for tightness.							
Check attachments for pin wear							
Check all hydraulic hoses and fittings for any leaks or wear							
Clean away any material build up around cylinder guide ways, spring apertures and the pin engagement surfaces.							

Weekly prestart check list

Thoroughly clean coupler	Week ending:
Check Coupler for evidence of fatigue, weld failure or stress. Do not operate with a cracked weldment.	
Repeat daily checks above.	

Operators Name & Signature:	Managers Name & Signature:

IMPORTANT SAFETY INFORMATION

The D-Lock range of Quick Hitch Couplers comply to AS4772-2008 Australian standard for Earthmoving machinery – Quick hitches (Couplers) for excavators and backhoe loaders AS4772-2008 Clause 2.1.4, Workcover NSW WC01783 position paper, European Standard EN474 and ISO13031.

Remember that on any job, YOU are the key to safety. Good safe practices not only protect the people around you; they are also your own best protection. Study this section and any relevant manufacturer's operation manuals covering your equipment. Read all warning and caution instructions.

1. This manual must be **READ** and **UNDERSTOOD** before any installation and operation work begins. A copy must be kept in the operator's cabin for ongoing use.
2. Operators should note that the use of a quick coupler may affect the machine's breakout force and balance and may result in attachments being able to come into contact with the boom set and or operators cabin.
3. Operators should note that the weight of the coupler is stamped on the ID Plate and this must be taken into account when calculating the machine's lifting capacity.
4. Doherty Engineered Attachments Couplers are designed for use with Doherty Approved attachments only. Approval must be obtained for use with non-Doherty attachments.
5. All Doherty couplers must be connected and installed in full compliance with this manual. Any variations may cause the coupler to operate in an unsafe manner and/or void the warranty. Doherty is available to advise on particular issues as required.
6. Due to the self tightening and automatic wear compensation features of this coupler it is recommended that the locking cylinder be disengaged at the end of each day.
7. The D-Lock Quick Coupler is designed to take up wear, however if mounting pin wear exceeds 5% of the original diameter, immediately replace implement pins. Refer to wear limits on page 23, 24.
8. All excavator operators should familiarise themselves with all coupler/attachment combinations before attempting to operate the coupler. This should include, but not be limited to, practicing engaging and disengaging each attachment. Furthermore, when new attachments are added to the machine's fleet, the operators should proceed with the same "familiarisation" process before it is used on the job site.
9. Never use the Coupler as a prying tool.
10. Never use the Coupler as a clamping device.
11.  **In the event of a loss of engagement failure, the Jaw Locking Pawls and compression units MUST BE REMOVED AND REPLACED**

PRODUCT IDENTIFICATION AND DECALS

All D-Lock Couplers are supplied with an ID plate attached as shown below. In addition, a serial # is stamped into the top edge of the Left Hand mounting plate. (Note, location of id badge on some models may differ).

	<p>Serial # stamped here</p> <p>SWL stamped here</p> <p>Manufactured By Doherty Engineered Attachments Ltd Made in New Zealand</p> <table border="1"> <tr> <td>Host Machine</td> <td>SWL (KG)</td> </tr> <tr> <td>Attachment Type</td> <td>WP (BAR)</td> </tr> <tr> <td>Serial Number</td> <td>Weight (KG)</td> </tr> <tr> <td>Manufacture Date</td> <td>Pin Dia</td> </tr> <tr> <td>Min Ctrs</td> <td>Max Ctrs</td> </tr> </table> <p>Ph +64 7 574 3000 www.dohertydirect.net Doherty products are patent protected Compliance AS4772-2008, WorkCover NSW-WC01783</p>	Host Machine	SWL (KG)	Attachment Type	WP (BAR)	Serial Number	Weight (KG)	Manufacture Date	Pin Dia	Min Ctrs	Max Ctrs
Host Machine	SWL (KG)										
Attachment Type	WP (BAR)										
Serial Number	Weight (KG)										
Manufacture Date	Pin Dia										
Min Ctrs	Max Ctrs										
	<p>Jaw Part # stamped here</p>										
	<p>Cylinder Serial # stamped here</p>										

It is recommended that a copy of these details be kept in the office for future reference.

PRODUCT IDENTIFICATION AND DECALS

 Manufactured By Doherty Engineered Attachments Ltd Made in New Zealand	
Host Machine	SWL (KG)
Attachment Type	WP (BAR)
Serial Number	Weight (KG)
Manufacture Date	Pin Dia
Min Ctrs	Max Ctrs
Ph +64 7 574 3000 www.dohertydirect.net Doherty products are patent protected Compliance AS4772-2008, WorkCover NSW-WC01783	

Always quote these details when contacting Doherty Engineered Attachments for Service or Parts.

In addition, your Doherty Attachment may be fitted with a number of **SAFETY and MAINTENANCE DECALS**. These decals must be kept clean, in good condition and be visible from a distance of 3 meters. Replacements for damaged decals may be obtained from the DEA parts department.

The D-Lock Coupler also requires that the following **OPERATOR DECALS** be fitted by the Installer in the machine's cabin. These must be clearly visible from the operating position and maintained in a clean and legible condition. These decals will be supplied in the same pouch as this manual – please check that all are included. Replacements for damaged or missing decals may be obtained from the Doherty parts department.

CONTACT WARNING DECAL:

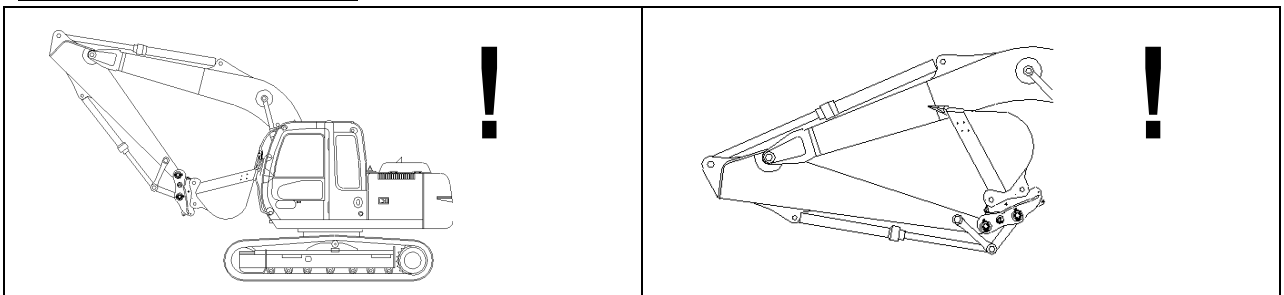

OPERATION DECAL:

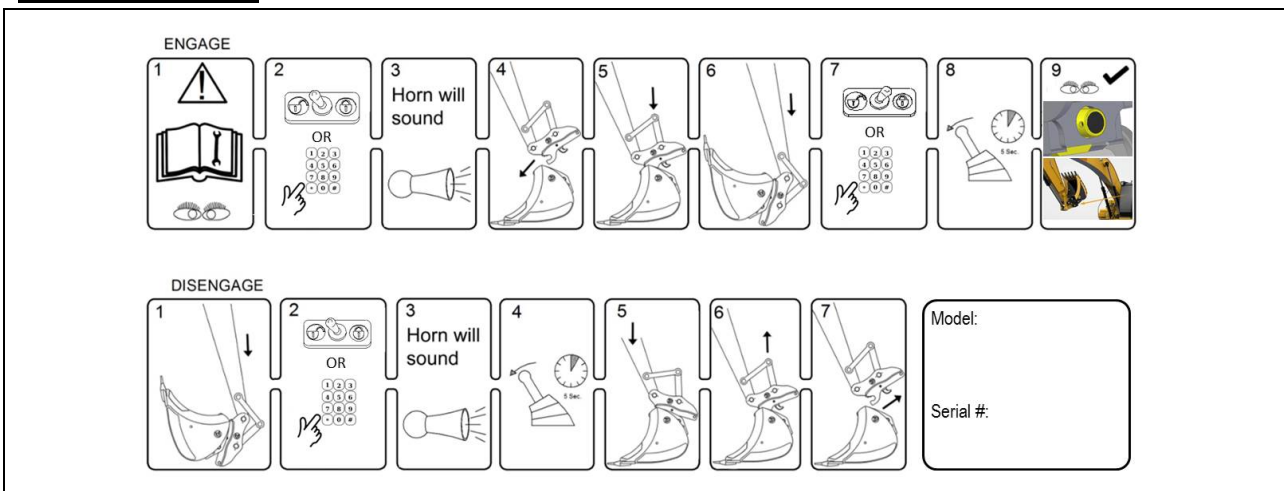

SUITABILITY OF ATTACHMENTS



Most excavator attachments with a two-pin connection system are suitable for use with the Doherty D-Lock range of couplers depending on the pin spread, pin diameter and weight. These include:

- Buckets
 - Digging, Trenching, Cleaning, Ditching, Mud, Riddle, Tilt buckets, Rippers, Rakes etc
- Clamshell buckets with two pin connection
- Hydraulic grabs and grapples and Hydraulic shears and pulverisers with two pin connection
- Flail mowers
- Compactors, Wheel, Drum, Plate



- **Hammers / Breakers ***

***DO NOT USE** oversize hammers / breakers, they must be correct size for the weight class of the Excavator and Coupler.

If a hydraulic hammer or breaker is to be used for an extended period, then it is recommended that the coupler is removed, and the hammer mounted directly to the machine.

The hammer should **ALWAYS** be used in the vertical position and **NEVER** use the hammer as a lever. Ensure the Coupler and all components are inspected frequently.



- **ALL attachments that operate while not operating the bucket crowd function MUST be used with the coupler in the vertical position. Failure to comply will void warranty and may lead to serious injury / death.**



DO NOT USE any oversized attachment. Attachments must be correct size for the weight class of the Excavator and Coupler. Use of any oversized attachment will make warranty void and could lead to serious injury / death.

Stiff arm attachments when used must be pivoted on the main dipper arm pin of the machine, NOT the front pin of the coupler open C section.

Hydraulic clamps / thumbs or similar MUST have pressure relief valves incorporated to prevent overloading the coupler.

If in doubt on attachment use, please consult Doherty.



DANGER - The Coupler MUST not be used with any attachment to transport or lift people.

PRODUCT SPECIFICATIONS

PRODUCT TECHNICAL SPECIFICATIONS: D-LOCK HD COUPLERS

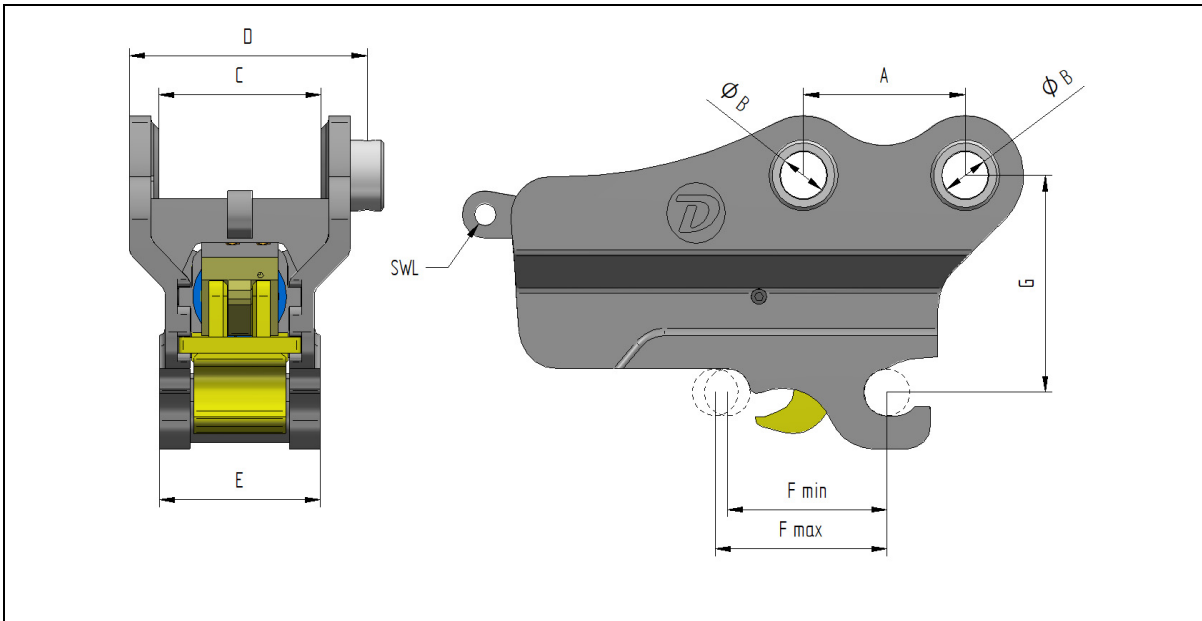

Excavator Class (Tonne)	Coupler Model	Pin centre F min F max (mm)	Pin Diameter (mm)	Weight (KG)	Width (mm) <i>No clippers</i>
1-1.9	HD015	Host machine -2/+6mm	30	From 20	To suit host machine
2 – 2.9	HD025	Host machine -2/+6mm	35	From 28	120

For models and dimensions not shown, please consult Doherty

INSTALLATION

IMPORTANT INSTALLATION NOTES

- Due to the large number of Excavator Makes and Models available, it is not possible to provide a rigid set of installation instructions that will cover every situation. Modern Excavator control systems are complex and sophisticated. Auxiliary connections must be carried out with care to ensure the manufacturer's warranty is not voided. It is therefore extremely important that only appropriately qualified and experienced persons carry out the installation. It is **STRONGLY RECCOMENDED** that the excavator dealer be consulted to ensure the auxiliary connections are correctly made.
- Installation personnel must be competent and experienced in this type of work.
- Best hydraulic practice will be used to ensure that all components remain clean and free of contamination and that all hoses are suitably routed and armoured to prevent, crushing, pinching or chaffing damage.
- The requirements detailed in this publication must be fully understood and complied with.
- No changes to the host machine's control systems should be made without express agreement by the manufacturer and or distributor.
- All current Health and Safety Regulations pertaining to this installation and subsequent operation must be complied with.
- The pre-delivery check sheets (including pressure readings) must be fully completed, signed and returned to Doherty.
- Contact Doherty for additional assistance, if required.
- Failure to comply with these guidelines may cause equipment damage and/or void any applicable warranty.

INSTALLATION

FITTING THE COUPLER

Remove any existing attachments from the machine.



1. **NOTE** Hardened pins **MUST** be used for this application do not use non hardened attachment pins.
2. **CLEAN** all bores and pin surfaces, pre-lubricate pins with grease and set aside on a clean surface.
3. Carefully align the link arm between the two bosses, which are furthest from the cab of the machine. Ensure the O rings are correctly positioned and fit one pin. Shim as required to eliminate excessive side float. **NOTE** Packers and Shim sets are available for your new coupler and are designed to fit the machine specified on the original sales order confirmation. Additional shims are available from Doherty Parts department if required.

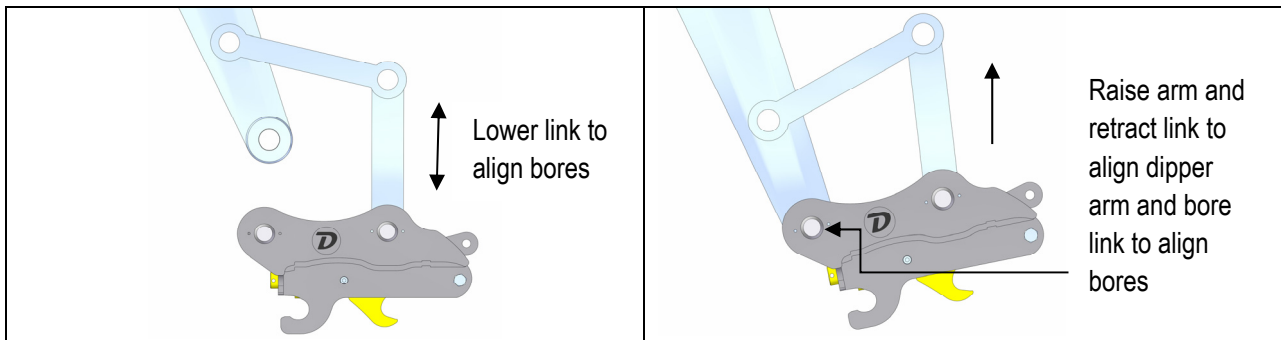

4. You can now lift the coupler off the ground and use the crowd and arm controls to accurately line up the main dipper arm bore. Position the O rings and fit the second pin. Shim as required.
5. Ensure the pin retaining bolts are fitted and tightened. Use Nyloc type or lock nuts with the supplied bolts for Doherty supplied pins.
6. Grease up both pivot points as required.
7. Using the excavator hydraulics, carefully crowd the quick coupler to the extremes of the crowd travel and check that there is adequate clearance between the coupler and the dipper arm surfaces and linkages.

CONNECTING THE COUPLER LOCK CIRCUIT

A. ELECTRICAL



The Lock/Unlock control is operated by an electrical solenoid valve via an approved switching device. This device must:

1. Incorporate an audible warning device.
2. Fail to safe (locked) mode in all circumstances.
3. Not be able to be accidentally operated
4. Include a self checking function when the engine started.

Doherty have available a purpose built fully compliant D-Lock Control Keypad which can be installed in the cabin and connected to the machine's electrical system as shown on the following schematic. Clients may fit other types of safety switches but must ensure compliance with all regulations.



NOTE: Some excavators are now equipped with factory fitted Quick Coupler lock/unlock controls. If these comply in your region then in general, these controls are suitable for use with Doherty D-Lock couplers, however

INSTALLATION

Doherty recommend that the D-Lock keypad to be used. Doherty will not take any responsibility for control switch if the D-Lock keypad is not used.

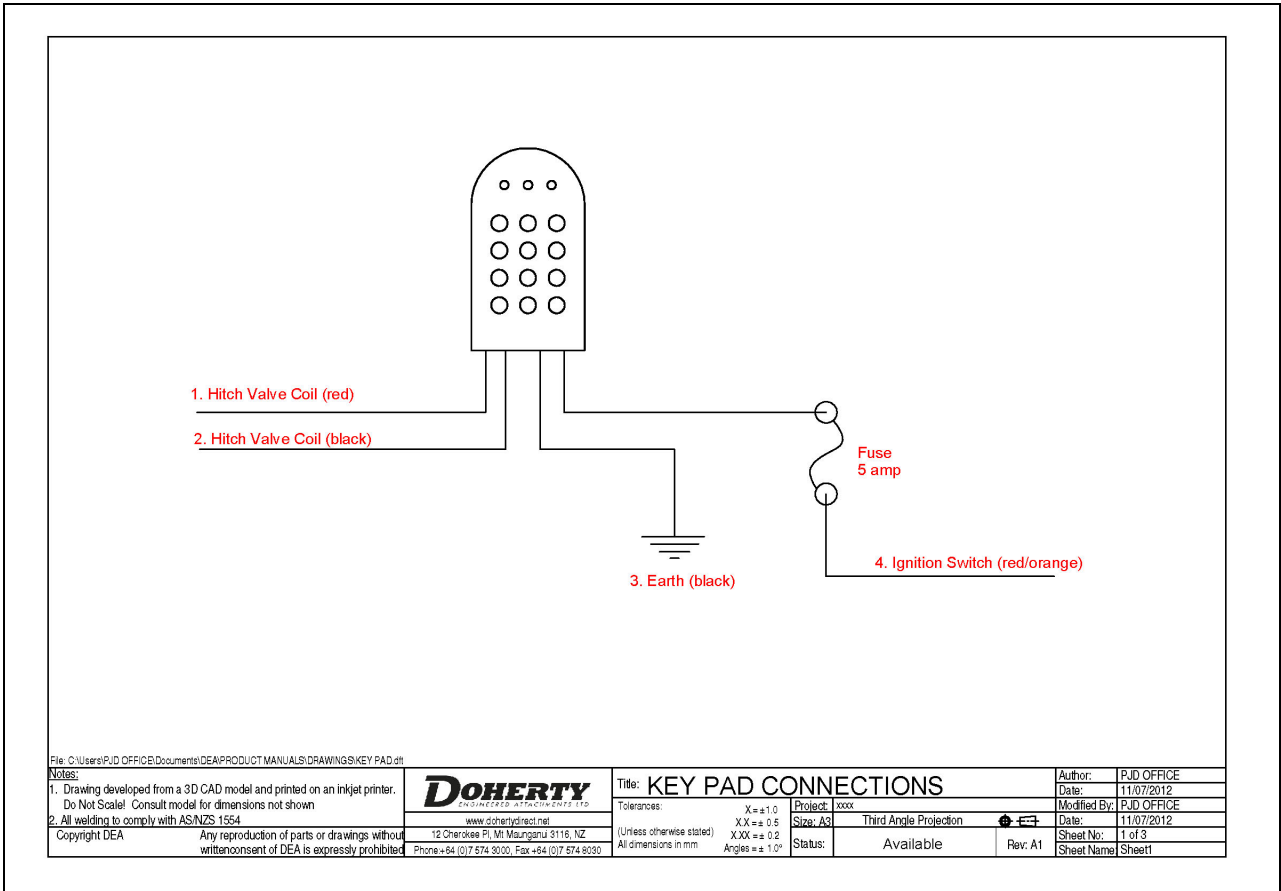

Approved keypads are available from Doherty Couplers & Attachments.

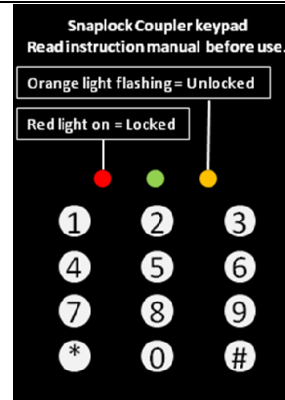

The default 4-digit pin is set to **5713#**



SETTING AND RESETTING OF THE KEYPAD 4 DIGIT CODE



INSTALLATION

The default lock / unlock code is factory set to 5713#, should you want to change the code to be different follow the instructions below:

Enter:	*7258*
Enter:	0#
Enter:	2#
Enter:	"new code" then #

B. HYDRAULICS

Doherty D-Lock Mini Couplers are designed to operate between 35 (Pilot Pressure) and 250 bar (500-3600 psi) using an approved control valve. The valve must be open to the locking port so that in the event of an electric problem, the coupler will always remain locked when the machine is operating. Approved Control Valves (12 and 24V) are available from Doherty and will be included as part of the Coupler Fitting Kit if this was ordered with the coupler.



It is the installer/dealers' responsibility to ensure that any factory fitted controls fully comply with all current Health and Safety Regulations.

Typical D-Lock Mini Coupler control circuit

INSTALLATION

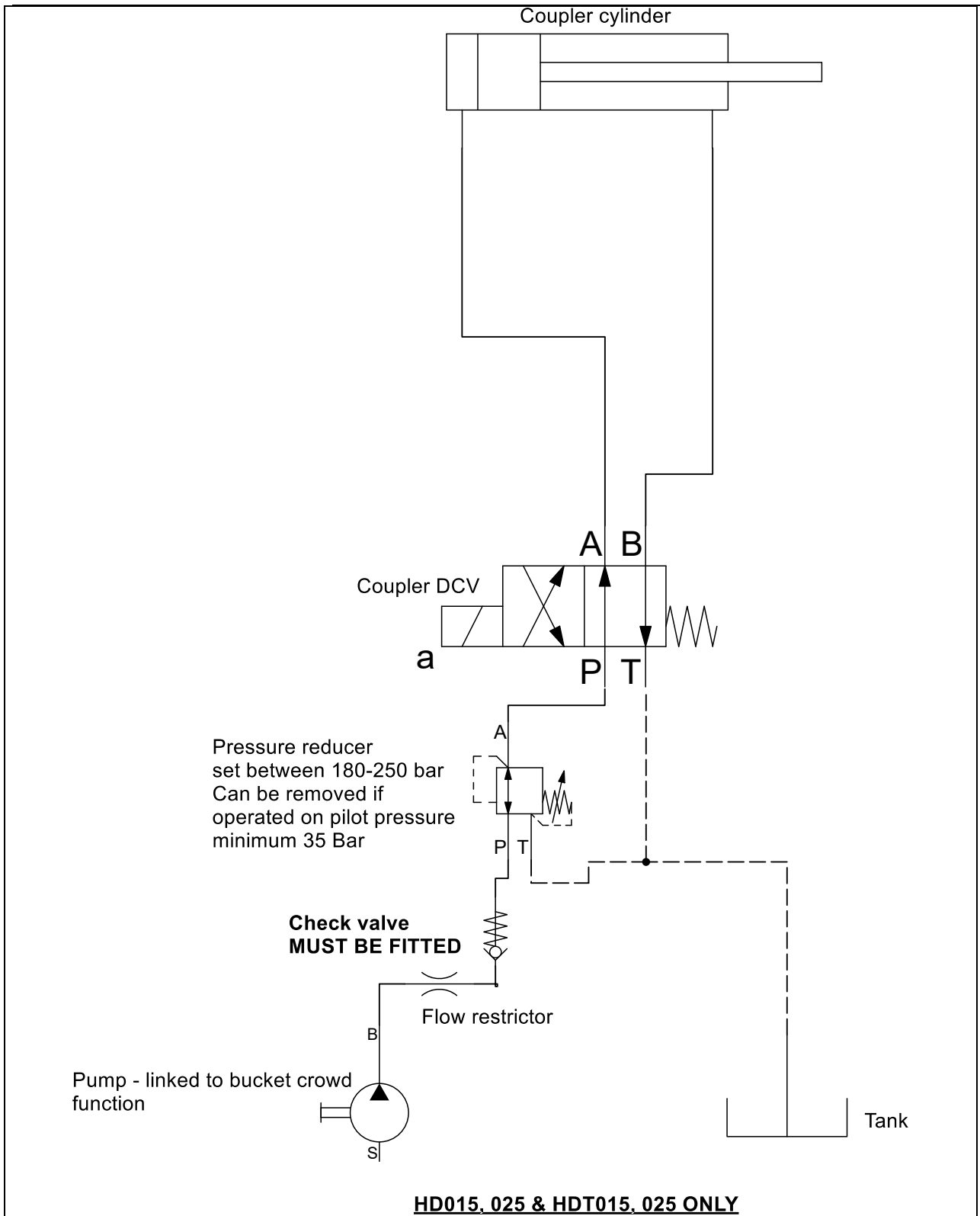

HYDRAULIC PIPING REQUIREMENTS.

INSTALLATION

For best performance, purpose run hydraulic tubing should be fitted to the boom and dipper arm. Two runs of 3/8" OD tube with 1/4 or 3/16 or hydraulic hose connections are required for the coupler lock / unlock circuit. Take care to ensure tube and hoses are properly secured and protected to eliminate chaffing and pinching during normal operations. 3/16 thermoplastic hoses may be used if space is limited PROVIDED they are fully sheath protected and routed to eliminate the possibility of kinking.

It is recommended that a manifold block be fixed to the end of the dipper arm as shown in the following drawing. This is a convenient place to connect the coupler control hoses and allows adequate room for hose movement during bucket crowding. Please ensure all new tubing and hoses are thoroughly cleaned (blown out) before final assembly.

To establish the correct control hose lengths, crowd the coupler right forward and make up hoses to suit. Take care when crowding back to ensure excess hose rolls up dipper arm and does not foul on anything. The use of kevlar sleeves or "spaghetti" armouring is strongly recommended.

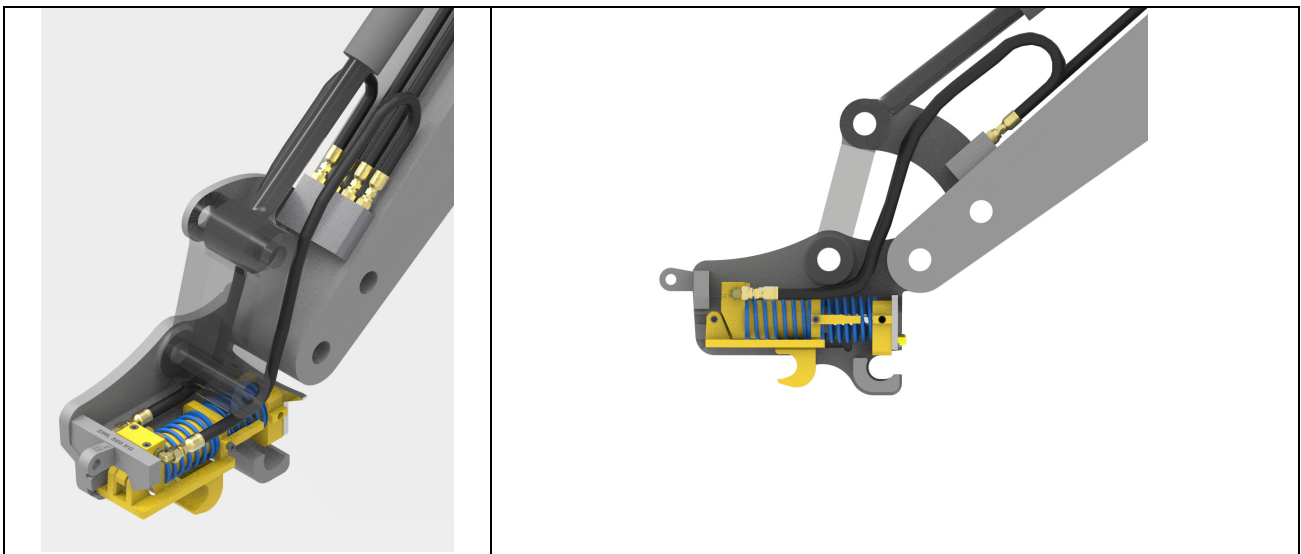

INSTALLATION

1	Verify all fittings and fasteners are tight and secure.	
2	Check the entire system for leaks.	
3	Move the Coupler through its entire motion slowly checking for: Hose chaffing Correct hose lengths and supports Any type of mechanical interference.	
4	Test the D-Lock control keypad, ensure alarm sounds and light flashes when in unlock mode.	
5	Attach and detach all attachments to be supplied with the machine and ensure coupler locks securely.	
6	Ensure that all product and cab decals are correctly fitted and visible.	
7	Complete Pre-delivery form and return to Doherty Engineered Attachments to activate warranty.	
8	Ensure this manual (or a copy) is placed in the operator's cab Additional copies of this manual are available in hard copy or electronic form from Doherty Engineered Attachments.	



OPERATION



CHECK ALL ATTACHMENTS BEFORE USE TO ENSURE THEY ARE CORRECT FOR THE COUPLER:

The Coupler is fitted with an ID tag which states the pin diameter and pin centre range it is designed for, ensure all attachments are checked before use. Attachments with pin dimensions outside the range specified on the ID Plate **MUST NOT BE USED**

Example on how to check:

Check pin diameter	Check pin centres	Check internal width
		
<p><i>Note, Internal width should not exceed the width of the coupler more than 4mm per side, If coupler is used on Under cutters, rock saws or any other attachment which has a significant side load the coupler MUST be a tight fit.</i></p>		



WALKING OF MACHINE

ALWAYS ensure you have the attachment in a curled *safe* position as shown.



OPERATION

LOCKING / UNLOCKING PROCEDURE





The D-Lock range of Quick hitch couplers comply to AS4772-2008 Australian standard for Earthmoving machinery – Quick hitches (Couplers) and requires a particular procedure for successful locking and unlocking which may vary from other couplers. **It is important that all operators fully understand the correct procedure as described and illustrated following.**

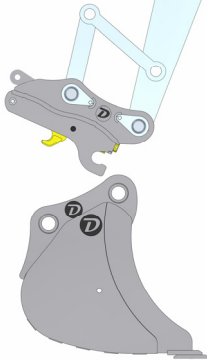
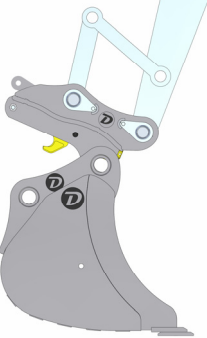
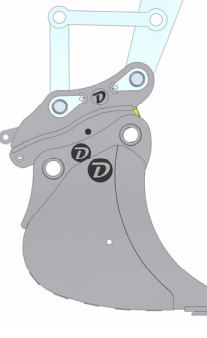

TO ATTACH:

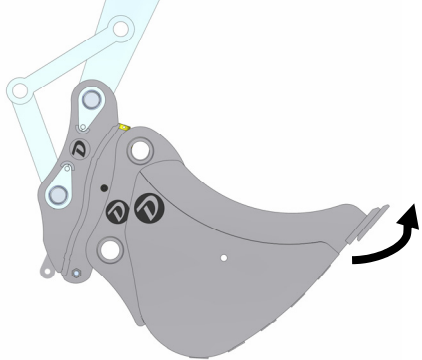
<p>STEP 1</p> <p>Place coupler in the fully curled/crowded position. Enter keypad code– the buzzer will sound. Hold the bucket crowd lever for approx. 3-5 seconds to allow the hook to fully retract. Visually inspect to check the hook and front lock is fully retracted.</p>	
<p>STEP 2</p> <p>After Ensuring that the jaw is fully retracted, place the coupler above the attachment.</p>	
<p>STEP 3</p> <p>Curl the coupler to engage the front pin.</p>	
<p>STEP 4</p> <p>Continue to curl the coupler until the attachment is lifted off the ground</p>	

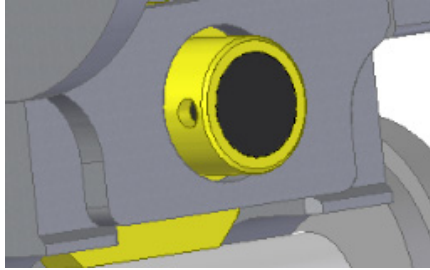
OPERATION

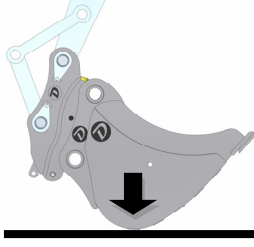
<p>STEP 5</p> <p>Fully curl/crowd the bucket. Re enter keypad code, the buzzer will cease. Hold the bucket crowd lever for approx. 3-5 seconds to allow jaw to fully engage and clamp the bucket pin.</p> <p> DANGER – If the bucket/attachment pins have not been correctly engaged the jaw MUST NOT be retracted. This could cause the bucket to be unintentionally released from the coupler and could result in machine damage or personal injury. Please refer to step 8 for remedial action.</p>	
<p>STEP 6</p> <p>Visually inspect and check that the rear jaw is engaged.</p> <p>If the front lock indicator is not visible:</p> <ol style="list-style-type: none">Fully extend the crowd cylinderRe enter key pad codeHold crowd on relief for 3-5 secondsRe enter key pad codeRepeat c above and visually check again.	 
<p>STEP 7</p> <p>If it is not possible to view this from the cab then the operator must get out of the cab and stand in a safe place to visually inspect before operating the machine.</p>	
<p>STEP 8</p> <p>To ensure that the bucket pins are securely held by the coupler, apply pressure to the bucket by rotating it against the ground and away from the machine before operation. If the bucket is not correctly attached, repeat the sequence from step 1.</p>	

OPERATION

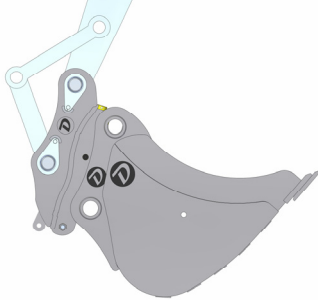
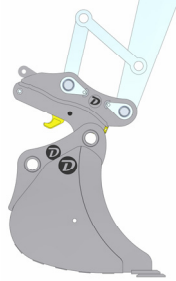
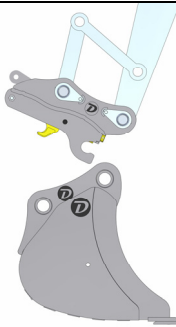

TO RELEASE:

<p>STEP 1</p> <p>Fully extend bucket crowd cylinder. Enter key pad code – the buzzer will sound. Hold the bucket crowd on relief for 3-5 seconds to allow the hook to fully retract.</p> <p> WARNING – Do not release or change the bucket near any person or in any areas that may result in an accident or injury occurring. The key pad should be in the attach or off position at all times, except during bucket changing.</p>	
<p>STEP 2</p> <p>Once the jaw and front lock is fully retracted, lower the attachment to ground and slowly curl the coupler back to release the rear bucket pin.</p>	
<p>Step 3</p> <p>Lift the dipper arm until the coupler has disengaged the front bucket pin. The attachment is now safety disengaged.</p>	

HANDY TIPS

1. Your Coupler should be unlocked on a daily basis to ensure satisfactory operation. This is particularly important when using hammers or digging in hard ground as the constant vibration can cause the wedged surfaces to become very tight.
2. If your machine is to remain inactive for an extended period we suggest that the attachment be released to eliminate the possibility of seizing.
3. Keep your coupler clean. Build-up of material in the pin contact areas will affect the locking effectiveness and may cause unlocking problems.
4. The operator may experience slow or unexpected movement of functions when operating with cold hydraulic oil. Likewise, damage to the hydraulic components may result due to cold oil. Make sure to warm up hydraulic system before operation.

OPERATION



OPERATIONAL SAFETY NOTES



Site Personnel must stay clear when engaging and disengaging a bucket or an attachment.



If Yellow Snaplock indicator is not protruding through the end plate the coupler is incorrectly attached. **DO NOT OPERATE.** Lower to the ground and carefully check for obstructions

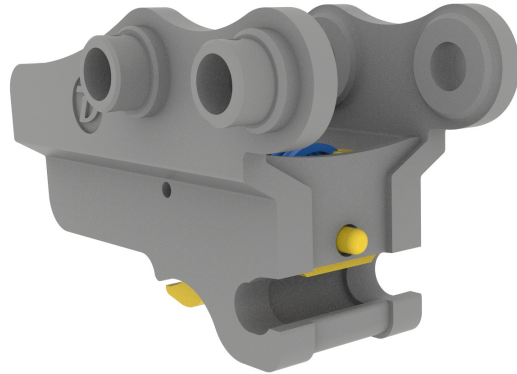

If alarm continues to sound after entering keypad code to LOCK there is an electrical fault. **DO NOT OPERATE THE MACHINE** until this is rectified.

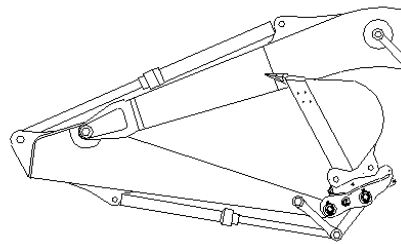
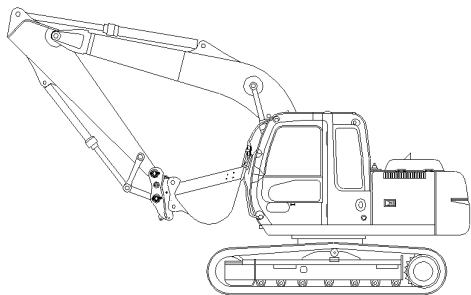

The installation of a quick coupler effectively lengthens the reach of your excavator's dipper arm. This may enable various attachments to come into contact with the boom set and operator's cabin. Operators must be aware of this and take appropriate care.

Due to the self tightening and automatic wear compensation features of this coupler it is recommended that the locking cylinder be disengaged at the end of each day.



USING THE LIFTING POINT.

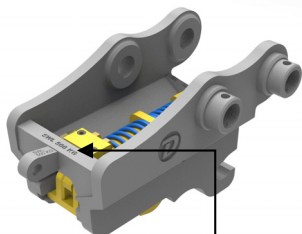

Fit Bow shackle as shown



These lifting points are designed for use only with certified Bow Shackles and no other fixing devices are to be used.

SWL stamped here

OPERATION



LIFTING SAFETY WARNING

Daily inspections of the lifting eye are required, check for any wear and defects.

The lifting eye **MUST** be formally checked every six months for wear or damage, see maintenance section for wear limits.



LIFTING SAFETY NOTES

1. The safe working load (SWL) in Kilograms is stamped adjacent to the lifting point and must not be exceeded. Note this rating must be checked against the machines lift chart ratings and the lower figure used in all situations.
2. The safe working load (SWL) is also noted on the ID Plate and in this manual. **THIS MUST NOT BE EXCEEDED** under any circumstances.
3. ALWAYS remove the attachment from the coupler before lifting.
4. ALWAYS ensure the Bow Shackle is in a vertical position when lifting.
5. Do not attach lifting chains or slings to any other part of the coupler.
6. NEVER allow chains to push against the sliding jaw.



LIFTING SAFETY WARNING

Daily inspections of the lifting eye is required, check for any wear and defects. Ensure decal below is fitted to Cab

<p>Lift when vertical and with the jaw fully retracted</p>	<p>Do not lift with jaw extended or with hitch horizontal</p>	<p>Do not lift from Open C</p>	<p>Do not lift from attachment</p>
	<ul style="list-style-type: none"> • Only use the lift eye on the D-Lock coupler • Only lift with the D-Lock coupler in the vertical position • Fully retract jaw before lifting with the D-Lock coupler • Do not lift from any attachment connected to the coupler • Do not exceed the lifting eye capacity (SWL stamped next to lift eye) • Do not exceed the rated lifting capacity of the machine • Use in a safe manner at all times 		

MAINTENANCE



LIFTING EYE WEAR LIMIT – 6 monthly or 1000hrs (whichever occurs first)

The lifting eye MUST be formally checked every six months for wear or damage, if the lifting eye wear is outside the tolerances shown in the chart below, do not use.

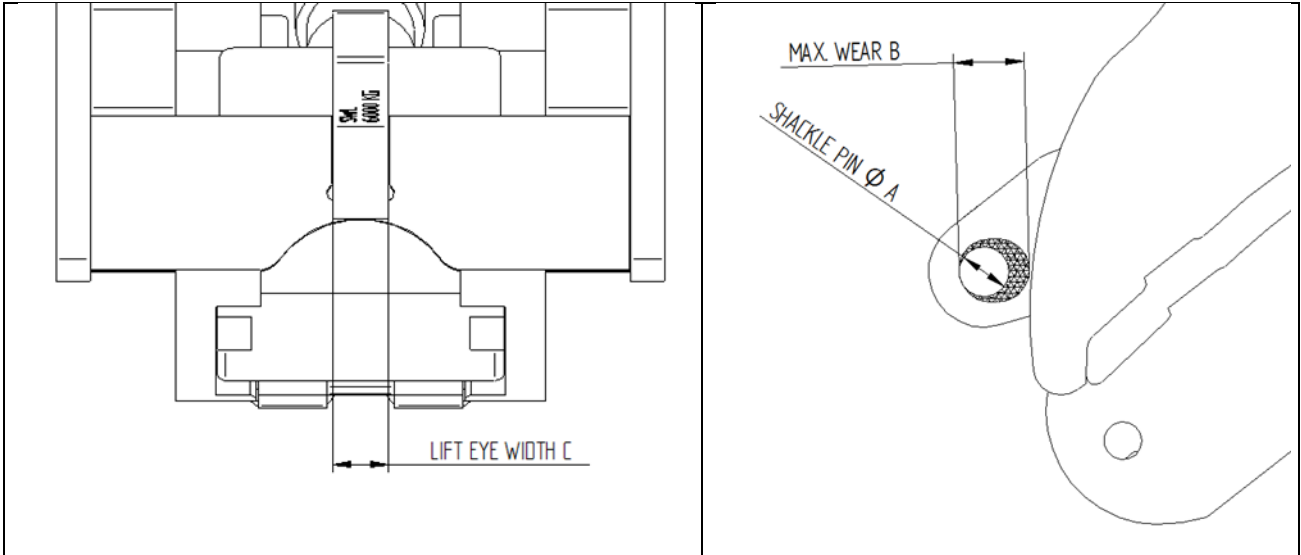

B must not exceed A plus 25% in any direction

Model	Lug Diameter	Max wear B		
HD015	14	4mm		
HD025	14	4mm		

MAINTENANCE



D-LOCK WEAR LIMITS – 6 monthly or 1000hrs (whichever occurs first)



The D-Lock quick coupler range **MUST NOT** be used if the wear limits below are exceeded:

Pin Size (mm)	WL 1 Open C (mm)	WL1 Open C Gauge No.	WL 2 Front Lock (mm)	WL 3 Attachment Pins (mm)
30	32	CG30	27	
35	37	CG35	32	33.5
40	42	CG-40	37	38
45	47	CG-45	41	43
50	53	CG-50	45	47
55	58	CG-55	50	52
60	63	CG-60	55	57
65	69	CG-65	60	61
70	74	CG-70	65	66
80	84	CG-80	74	76
90	95	CG-90	83	85
100	105	CG-100	92	95
110	114	CG-110	102	104
120	126	CG-120	111	114
130	137	CG-130	120	123

How to check wear limits

	<p><u>Open C (WL 1)</u></p> <p>Fully retract jaw so that front lock is in the disengaged position. Try fitting a test gauge (available from your Doherty dealer) into the open C by rolling into the base of the C from the front. If the gauge fits all the way into the back of the open C then the wear limit has been reached and the open C must be built back up to the original diameter.</p>
	<p><u>Front Lock (WL 2)</u></p> <p>Fully extend jaw so that front lock is in the locked position. Measure from point to point as shown. If the measurement exceeds that in the table then the lock on the cylinder or the open C must be built up back to original dimensions.</p>

MAINTENANCE

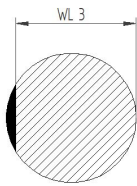
		<p><u>Implement Pins (WL 3)</u></p> <p>The diameter of the pins of the attached implement should be checked as per below. Measure for both wear on the circumference and also any flat spots. Any pins measuring undersize as listed should be replaced.</p>
---	---	---



OEM mounting pins diameter should be checked against the suppliers recommendations. Replace pins if required.

Jaw Wear

Inspect the contact surfaces of the Jaw. If there is evidence of the rear pin contacting the radial surface of the jaw then the wear limit has been reached and further inspections listed below must be made.

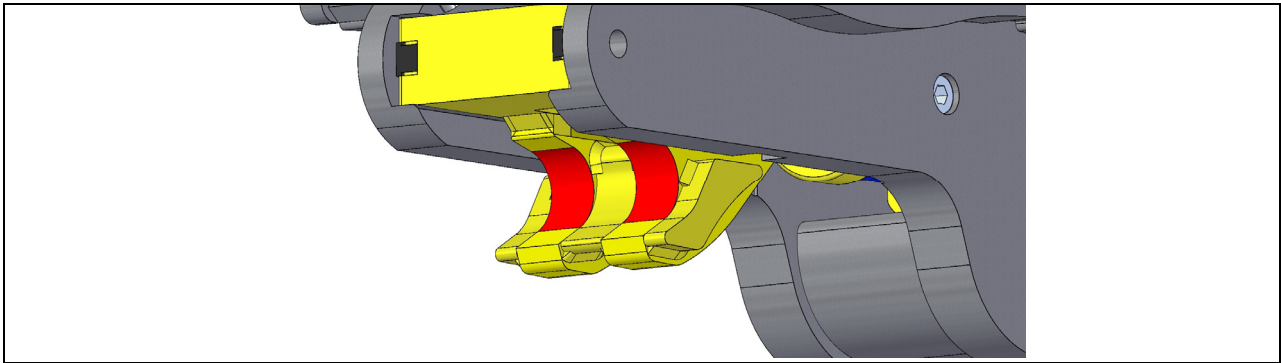

There are three wear areas that could be causing contact. It may be one area that is worn excessively or any combination of all three areas. All three areas should be checked and rectified if the below wear limits are exceeded.

Pin Size (mm)	WL 4 Body Rear Pin surface (mm)	WL 5 Jaw Contact surface (mm)	WL 6 Jaw Rails (mm)
30	1.5	6	2.5
35	1.5	8	2.5
40	2	14	3
45	2	12	3

MAINTENANCE

How to check wear limits

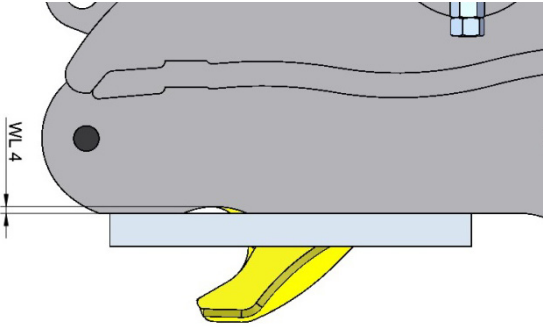
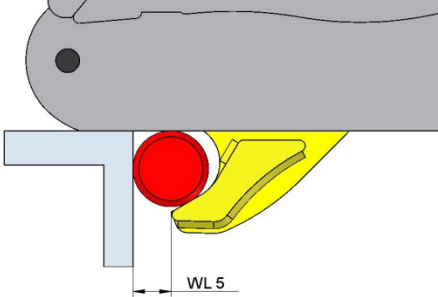
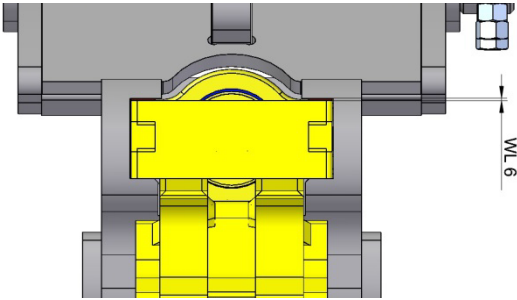
	<p><u>Body Rear Pin Surface (WL 4)</u></p> <p>Place straight edge along rear pin contact surface. Measure any gap between straight edge and surface. If the wear limit is exceeded the surface must be built up and ground back to original dimension.</p>
	<p><u>Jaw Contact Surface (WL 5)</u></p> <p>Place a square between rear pin contact surface and pin. Measure dimension and if it is less than the wear limit then the contact face of the jaw must be built up to original dimensions.</p>
	<p><u>Jaw Rail Clearance (WL 6)</u></p> <p>Measure the distance from the top of the jaw to the top edge of the jaw slot. If the gap exceeds the dimension shown then additional checks must be made. (see Jaw Rail Checks)</p>

MAINTENANCE

Jaw Rail Checks

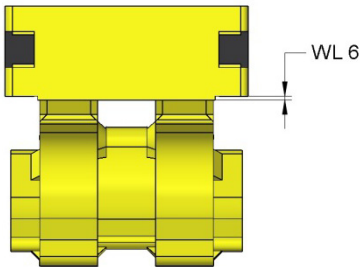
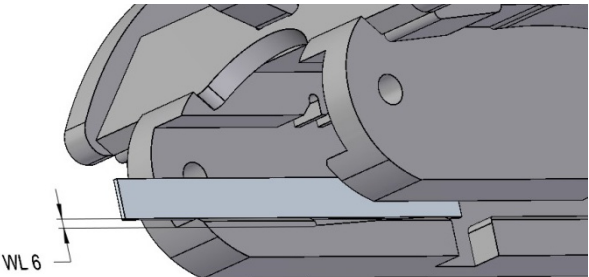
	<p><u>Jaw Check</u></p> <p>Remove jaw from hitch body. Inspect jaw base plate for any grooving on the underside. If the grooving exceeds the WL 6 limit the jaw base plate must be built up and ground back to original dimensions.</p>
	<p><u>Jaw Rail Check</u></p> <p>Remove jaw from hitch body. Place a straight edge along the lower rail surface. If there are any gaps that exceed the WL 6 limit then the hitch body must be taken out of service.</p>

JAW Safety Tip Wear (HD015 & 025 Mini Couplers only)

All HD015 - 025 model Jaws have a horizontal NIB or BEAK on the tip. This small but important feature prevent the rear pin from disengaging the jaw in the event of a loss of hydraulic pressure.

The condition of the jaw tip should be checked daily and measured weekly

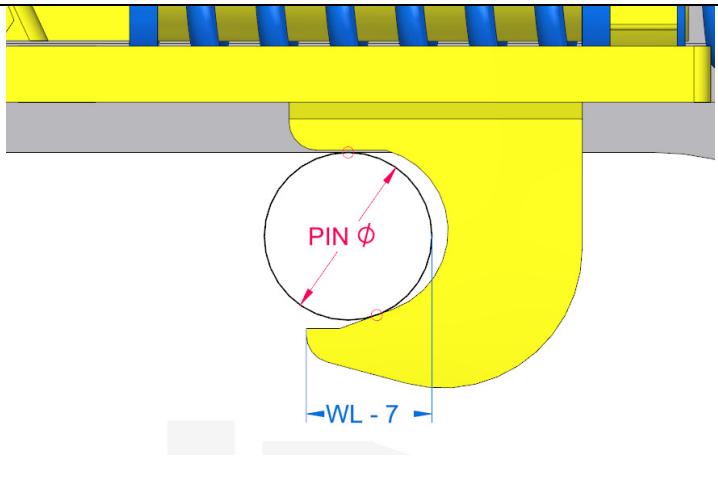
Pin Diameter (mm)	WL - 7 (mm)	
30	17	
35	21	
40	24	

MAINTENANCE



Daily Prestart Check

1. Disengage attachment from coupler.
2. Check all attachment pin retainer bolts and nuts for tightness.
3. Check attachments for pin wear - The D-Lock Quick Coupler is designed to take up wear, however if mounting pin wear exceeds 5% of the original diameter, immediately replace implement pins. Refer to Page 24.
4. Check all hydraulic hoses and fittings for any leaks or wear.
5. Clean away any material build up around cylinder guide ways, spring apertures and the pin engagement surfaces.
6. Thoroughly clean coupler.
7. Check Coupler for evidence of fatigue, weld failure, cracks or stress. Do not operate with a cracked weldment.
8. Repeat daily checks above.



Weekly

1. Thoroughly clean coupler.
2. Check Coupler for evidence of fatigue, weld failure, cracks or stress. Do not operate with a cracked weldment.
3. Repeat daily checks above.



INSPECTION SAFETY NOTES

Report necessary repairs. If your daily check uncovers any item that needs attention, repair, replacement or adjustment, REPORT IT NOW! The most minor defects could result in more serious trouble. If the machine is operated, only perform the work you are authorised to do. Do not attempt repairs you do not understand.

Check for broken, defective or missing parts and replace them. Keep equipment clean and free of dirt and oil so you can spot loose or defective parts.

Any damage to the Coupler should be reported immediately to either your site manager or directly to Doherty Engineered Attachments Ltd.



Annually or 2000 hrs (whichever occurs first)

4. Check all pin contact surfaces for wear. Build up and machine as required.
5. Remove Jaw and Check Condition of Safety Pawls. Any sign of deformation or wear indicates the need for **REPLACEMENT**.
6. Replace the Pawl springs/rubbers annually.



IMPORTANT CAUTION – WELDING

MAINTENANCE

Do not weld directly to the Quick Coupler without Doherty Engineered approval.

Do not weld any attachment while it is connected to the coupler. This may result in internal arc damage to the cylinder and void any applicable warranty.

Always disconnect machine battery before any welding work is started.



CAUTION

Never allow a hydraulic line or component to become contaminated. This could cause severe system damage. Contact an authorised machine distributor to obtain proper caps and plugs to be used on this machine.



MAINTENANCE SAFETY NOTES

Improper operation and maintenance of this equipment could result in serious injury or death. Read the operator's manual and this book thoroughly before operating and/or maintaining this equipment.

Maintenance should only be performed by experienced and qualified personnel

Always wear protective clothing when performing maintenance.

Avoid oil spills. Use containers, rags, and/or absorbent towels to contain any oil leakage. Dispose of all waste oils, fluids, lubricants and other hazardous waste property

Do not operate the machine with a defective quick coupler. Inspect the Quick Coupler and all components before starting operation. Perform any necessary repairs before operating the Quick Coupler.

Make sure the Quick Coupler and any attachments connected are resting on the ground and properly supported before performing any work on the Quick Coupler.

Unauthorised modification to the Quick Coupler or any of the Quick Coupler components may impair function, affect performance and/or affect the life of the quick coupler and the excavator. Unauthorised modification may impair personnel safety. Unauthorised modification will void your warranty.

Under normal conditions, all machine hydraulic circuits are under extreme pressure. When inspecting for leaks, use a small piece of cardboard, wood or metal to locate leakages. Small (pinhole) leaks can be dangerous if contact with skin or eyes is made. Wear approved safety glasses and/or face shield, gloves, hard hat, safety shoes, and work clothes during all inspection and maintenance procedures.

All coupler/attachment combinations should be checked for possible interference before using. Ensure that the coupler engages and disengages properly and easily.

Always relieve hydraulic pressure before removing hydraulic fittings.

TO REMOVE CYLINDER

MAINTENANCE

Vent pressure in hydraulic lines. Disconnect at the cylinder and plug all open ports and fittings.

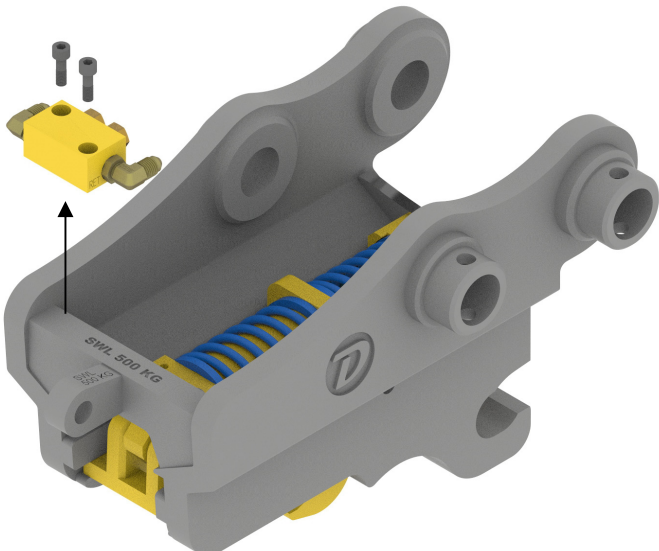
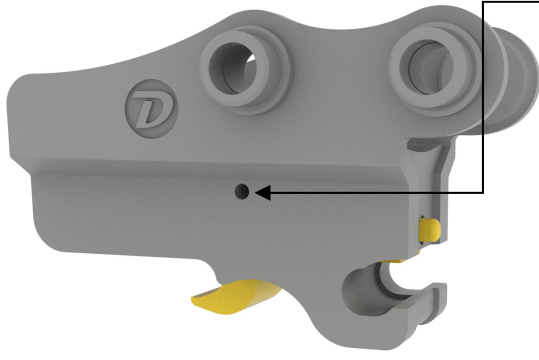
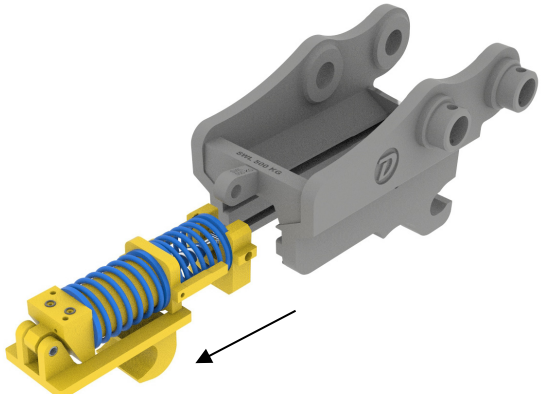
	<p>Remove cylinder manifold and hosing</p>
	<p>Remove spring locator cap screws from both sides.</p>
	<p>Slide the jaw, spring locator and cylinder out the end as one. The jaw retaining pin can now be driven out to release the cylinder.</p>

TORQUE SETTINGS AND PORT SIZES

Recommended Bolt Torque

Thread Size	Cap Screw (Gr 12.9)	Bolt (Gr 8.8)
	Nm (ft-lb)	Nm (ft-lb)
M6	18 (13)	12.1 (8.9)
M8	43 (32)	29 (21)
M10	85 (63)	57 (42)
M12	146 (108)	98 (72)
M14	233 (172)	157 (116)
M16	355 (262)	240 (177)
M20	696 (513)	470 (347)
M24	1199 (884)	809 (597)
M27	1749 (1290)	1183 (872)
M30	2385 (1759)	1613 (1190)



Note: Using copper/graphite thread lubricant and Nordlock Washer



Note: Do not use thread lubricant. Overtightening may damage seals.

Spring Locator Screws

Thread Size	Cap Screw (Gr 12.9) Nm (ft-lb)	
M10	85 (63)	
M12	146 (108)	



Note: Using thread locking agent and no washer

Port sizes of hydraulic cylinder

Coupler Model	Port Size
HD015-025	1/8 BSP
HD055-HD290	7/16 JIC
HD350 & ABOVE	1/4 BSP

PARTS LIST & TERMINOLOGY

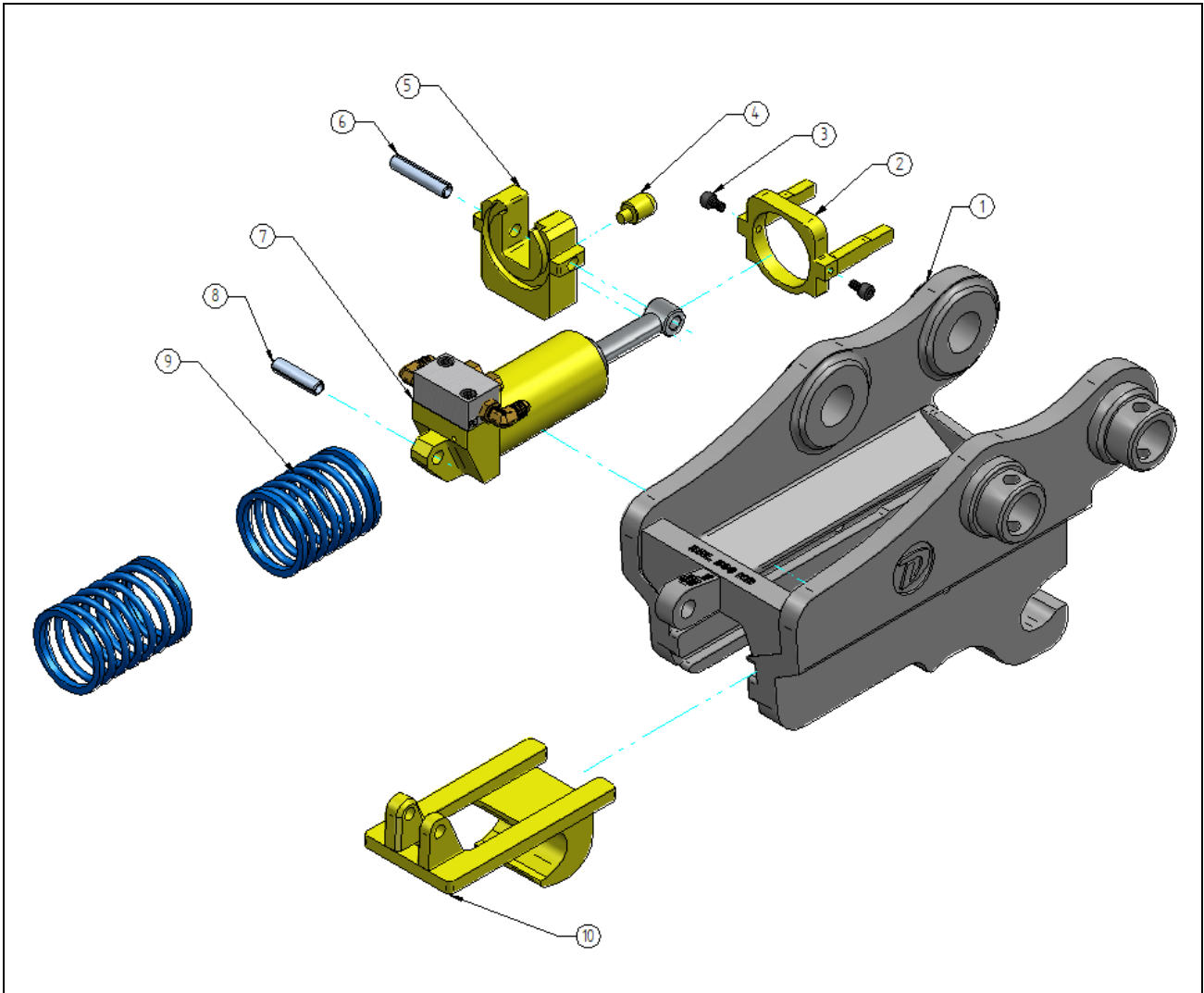

REFERENCE #	DESCRIPTION	QUANTITY	REFERENCE #	DESCRIPTION	QUANTITY
1	HITCH BODY	1	8	Jaw Roll Pin	1
2	SPRING LOCATOR	1	9	Spring	2
3	M6 x 10 Cap Screw	2	10	Jaw	1
4	Lock Indicator	1			
5	Jaw Lock	1			
6	Jaw Lock Roll Pin	1			
7	Cylinder	1			



Always quote make and model of excavator and serial number of coupler when ordering parts, this is a reference guide only.

PARTS LIST & TERMINOLOGY

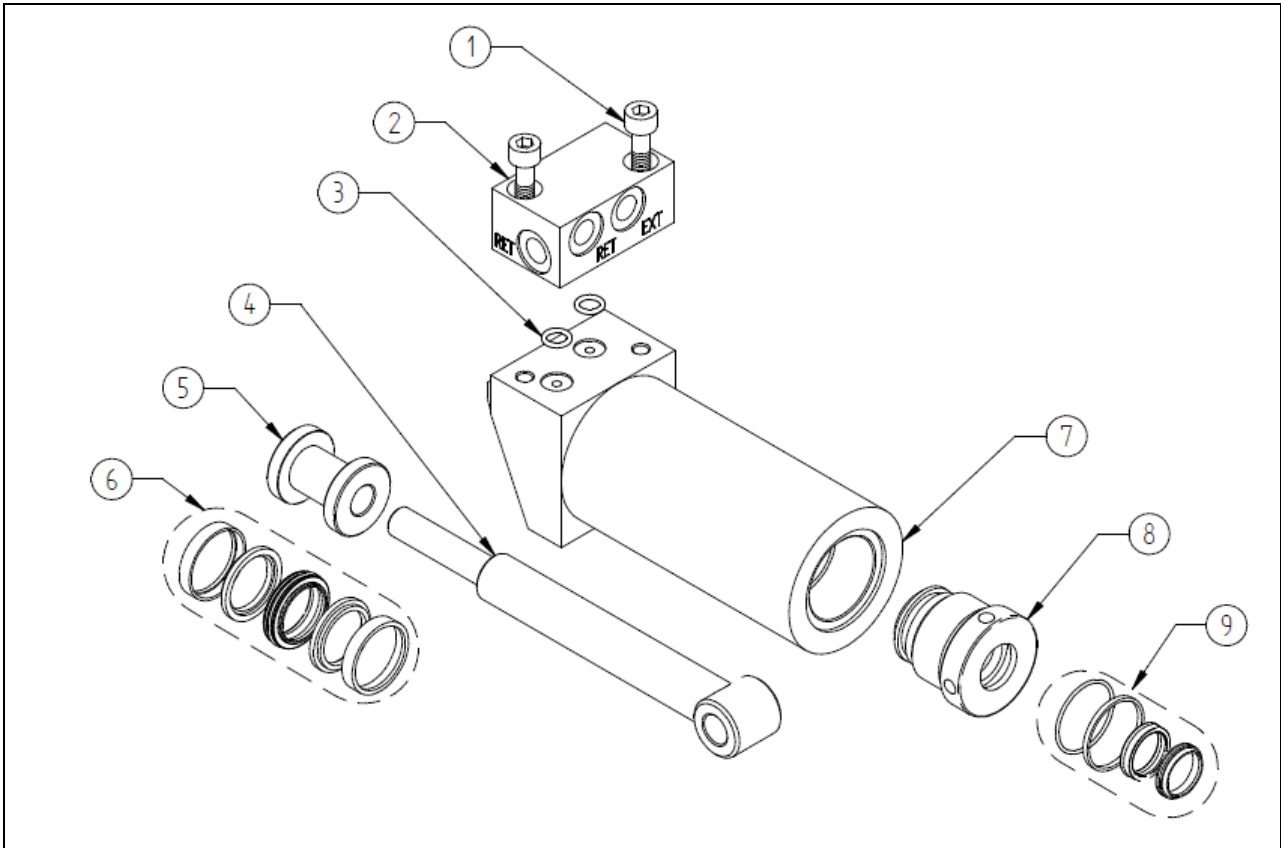

ITEM	PART NAME	NOTES	QTY
1	M6 x 10 Cap Screw	90009048	2
2	Manifold Block		1
3	O Ring -010N90	010N90	2
4	Spear	154 220 3010	1
5	Piston	XCEL – PISTON 25mm	1
6	Seal Kit 1	XCEL SEAL KIT 25 x 16	1
7	Cylinder	HD 015-50_A1	1
8	Gland	XCEL HEAD 25 x 16	1
9	Seal Kit 2	XCEL SEAL KIT 25 x 16	1



Always quote make and model of excavator and serial number of coupler and cylinder when ordering parts, this is a reference guide only.

TROUBLESHOOTING

Troubleshooting - Quick coupler

Functional fault	Cause	Remedial measures
Coupler not locked tight on implement pins	<p>Incorrect Pin diameter</p> <p>Pin centres not within Coupler specification</p>	<p>STOP WORK IMMEDIATELY</p> <p>Check coupler id tag for correct pin size and replace</p> <p>Check coupler id tag for correct pin centre range and ensure implements are within specification</p>
Coupler cylinder retracting under load	<p>Low operating pressure</p> <p>Faulty check valve</p> <p>Faulty cylinder seals</p> <p>Use of overweight implements for coupler model</p> <p>Faulty relief valve</p>	<p>STOP WORK IMMEDIATELY</p> <p>Check hydraulic pressure and adjust as required</p> <p>Clean or replace check valve</p> <p>Replace seals</p> <p>STOP WORK Consult Doherty for approved Implements</p> <p>Check Replace is set at 350 Bar and test, if problem remains present STOP WORK and consult Doherty</p>
Cylinder will not remain retracted when in unlock mode	No Check valve fitted on Pressure line	Fit as per Schematic
Coupler will not unlock	<p>Solenoid valve not operating</p> <p>Low operating pressure</p> <p>Locking Pawls remain in engaged position</p>	<p>Check wiring to solenoid valve coil</p> <p>Adjust</p> <p>Manually override, inspect locking pawls and jaw pin, replace if required.</p>
Sliding jaw is slow to extend / retract	Possible cylinder seal bypass	Preform bypass test and replace if bypass present

TROUBLESHOOTING

Functional fault	Cause	Remedial measures
	Check the operate is crowding the bucket cylinder to create machine pressure Incorrect installation	Crowd the bucket cylinder to overcome low idle pressure Refer to Doherty schematic
Sliding jaw jammed	Foreign material present	Stop use and remove foreign material
Keypad not working	Loose / faulty wires Faulty machine fuse Faulty ground wire Faulty Keypad	Check wires Replace machine fuse Check ground wire Replace keypad

WARRANTY POLICY

Standard Limited Warranty Policy

Warranty Period

Doherty Engineered Attachments Limited ("Doherty") standard warranty is for a **period of twenty four (24) months from date of sale or three thousand (3000) machine hours, whichever occurs first** from date of commissioning but not longer than thirty (30) months from the date of purchase.

Any repair or replacement shall not result in an extension of the original warranty period. Doherty's sole and exclusive liability for defects in materials and workmanship shall be limited to repair or replacement of the unit. Replacement will be like for like unless decided by Doherty's to replace with new product. Doherty's shall not be liable for incidental, contingent or consequential damages.

If examination by DOHERTY or its Contracting Partner results in a determination that the Product is defective in workmanship or material, subject to the warranty scope and limitations, the Product will be repaired or replaced (or credited) at no charge. If the Product upon such examination is found to not be defective in workmanship or material (for example, if the Product is not functioning properly due to abnormal use, improper service, or alteration, modification or parts usage), then such repair or replacement, if any, will be performed by DOHERTY or an Contracting Partner at normal servicing charges to the purchaser plus shipping costs.

Warranty Inclusions

This warranty covers defects in material and workmanship and is subject to receipt of supporting evidence and/or inspection by Doherty and confirmation that said attachment or part was installed and operated in accordance with Doherty's currently published instructions. Upon acceptance, Doherty shall repair or arrange for the repair and/or full or partial replacement of such attachment.

Any attachment or part repaired or replaced under the terms of this warranty policy shall retain the warranty period pertaining to the product's original date of purchase.

Transport

The cost and risk of transporting the allegedly defective Product to DOHERTY or its Contracting Partner will be borne by the purchaser, and the cost of transporting the corrected Product back to the purchaser will be borne by DOHERTY or the Contracting Partner. (If the allegedly defective Product that purchaser sends to DOHERTY or a Contracting Partner is not defective, the purchaser will also bear the cost of the transport of the product back to the purchaser.)

Warranty Exclusions

This policy does not cover machinery, parts or accessories that are warranted directly to the end user by third party manufacturers, for example hydraulic cylinders, hoses, valves, or any other portions of hydraulic kits used in Doherty products but not manufactured directly by it. Failure to follow Doherty's or the third-party manufacturer's recommendations for oil pressure and flow ratings on hydraulic components will invalidate all warranty claims relating to both the attachment and the hydraulic components of the attachment.

Doherty shall not be responsible for any problems associated with hose fittings, damage or malfunction after installation regardless of cause. If in doubt, contact Doherty for assistance and advice. The tightening of loose fittings or hoses is to be considered a maintenance issue, therefore any hydraulic leaks due to loose fittings is not covered under warranty.

WARRANTY POLICY

This policy does not apply to parts which have been repaired by the owner or a third party without prior formal written authorisation from Doherty.

This policy does not apply to parts which in Doherty's opinion, have been subjected to or adversely affected by operator misuse, accident, negligence, improper installation, maintenance, or storage.

Normal wear parts and parts requiring regular lubrication are not covered by this warranty.

This policy is restricted to the direct repair and/or replacement cost of the said part. It does not apply to any incidental or consequential costs such as travel, injury, accident downtime, consumables and any other indirect expenses.

Doherty accepts no responsibility whatsoever for the suitability or otherwise of the carrier machine or other equipment to which a Doherty attachment may be mounted upon or fitted to.

Doherty shall not be held liable for injury or damage caused to any persons, place or machine by reason of the installation, use or mechanical failure of any Doherty attachment.

Doherty shall be under no liability in respect of any defect in the goods arising from any drawing, design or specification supplied by the buyer.

In relation to the supply of buckets by the seller the above warranty shall only apply to cracking and bending of the buckets during correct and normal usage and shall not extend to the breakage of or failure of bucket teeth, cutting edges, bucket sides or base or to any other failure in performance due to a bucket being used in applications outside of its intended specified applications, including for example where a general purpose bucket or heavy duty bucket is used for rock and concrete excavations.

Doherty shall be under no liability under the above warranty (or any other warranty, condition or guarantee) if;

- A. The total price of the goods has not been paid by the due date for payment.
- B. The warranty or repaired part expires at the same time as the original warranty of the supplied equipment.
- C. Excessive diagnostic costs are involved in determining the validity of the warranty. This includes Labour, Travel and mileage.
- D. Deteriorated or failed components such as: Electrical wiring and connections, Hydraulic hoses, fittings, seals and cylinders where the cause has originated from chemicals, falling objects, dirt, salt and sand, rust, corrosion, moisture or extreme environmental temperatures and/or conditions.

Doherty Obligations

At its option, Doherty will repair or replace the said part. Any repair work may be carried out at Doherty's own premises, at the workshop of an authorized Service Agent/Dealer, on the site at which the part or attachment is being used, or at any other location that Doherty considers appropriate under the circumstances.

Under the terms of this warranty, Doherty's obligations are limited to the repair or full or partial replacement of the defective item(s) and do not include any costs, direct or indirect, associated with the removal or reinstallation of the attachment or part on the carry machine. This is the responsibility of the Customer.

Doherty warrants that any repair work carried out by it directly shall be conducted in a timely and professional manner. Where a third party is engaged to carry out repair work in connection with a Doherty warranty claim, Doherty's obligation and liability shall be limited to a refund of the authorized reimbursable costs charged in connection with the provision of such work.

WARRANTY POLICY

Customer Obligations

The Customer is responsible for the correct and proper installation of the part or attachment as detailed in the Operation and Maintenance documentation supplied by Doherty, including hydraulic and electrical connections.

The Customer is responsible for the completion of the formal Pre-delivery check and the Warranty Registration forms (which form part of the above documentation) and their return to Doherty within seven days of initial commissioning.

The Customer is responsible for ensuring that the part or attachment, including any hydraulic components and fittings, is operated and maintained using best industry practice and in accordance with the Operation and Maintenance documentation supplied by Doherty. (a copy of which is available on request.)

The Customer is also responsible for notifying Doherty as soon as it identifies a defect or problem that may potentially be subject to a claim under this policy and for following Doherty's published Warranty Claim Procedure.

Schedule of Rates

Unless a separate schedule of warranty rates is agreed prior, the rates below will be applicable to claims where the warranty procedure has been adhered to completely:

Parts	Free issue
Labour	\$75.00 per hour flat rate. Penal rates will not be covered
Travel	\$1.00/ km. To a maximum of 300 km AND a maximum travel time of four (4) hours per warranty claim
Freight	Use of Doherty freight account by negotiation

WARRANTY PROCEDURE

Warranty Claim Procedures

To ensure your warranty claim is processed in the fastest possible manner, please ensure the following procedures are followed:

1. Upon identification of problem/failure immediately report/notify Doherty before any work is completed on the attachment or component.
2. Complete the Doherty product issue assessment form and provide all information requested and email to Doherty before any work is carried out. If the product issue assessment form cannot be completed, Doherty is to be provided with the end-user details to obtain the required information.
3. Upon receipt of the product issue assessment form Doherty will assess the claim, in some cases Doherty may require the parts to complete assessment. Doherty will then provide in writing what action is to be taken and issue a warranty claim number if deemed warranty.
4. Any repair work may be carried out at Doherty's own premises, at the workshop of an authorized Service Agent/Dealer, on the site at which the part or attachment is being used, or at any other location that Doherty considers appropriate under the circumstances.
5. An estimate of costs must be provided in writing before any repair work commences by a third party who is not an authorised service agent/dealer and an order number MUST be provided by Doherty before any work commences.
6. If Product issue form has not been provided, Doherty will require a Purchase Order for any parts before dispatch. Once all information is received and warranty approved Doherty will invoice out at \$0.00
7. Where Doherty has opted to replace a product in part or in full, the defective components to be replaced will be dispatched as quickly as possible. Please ensure part numbers are quoted from parts manual if applicable.
8. It is the responsibility of the Customer to arrange for the delivery of the failed components.

All warranty claims are subject to Doherty's standard warranty policy.

Any repair work carried out by a third party prior to a warranty claim number and or purchase order number been issued by Doherty will invalidate the claim. All Invoices for repair work completed by a third party must include warranty claim & purchase order number, component serial number, description of work completed, and date work completed.

Contacts:

New Zealand: Phone +64 7 574 3000, email nzsupport@dohertydirect.net and cc your local Doherty contact.

Australia: Phone 1800 057 021, email support@dohertydirect.net and cc your local Doherty contact.

Product Issue Assessment Form

Date	PIR # (Internal use)

Contact Information

Company	Contact	Phone
	Email	Mobile

Site address & delivery details

Provide full details

Product details

Serial number	Model	Description	Purchase date & PO #
Excavator Make	Excavator Model	Hour Metre reading	Failure Date

Reported Issue

Description of problem, please provide all details, photo's, video and any other information to support claim, add additional pages if required.	
Action Required	Date Required

Estimated repair costs

Only required if work is getting carried out by a third party which is not an authorised service agent/dealer. Please ensure estimated hours and rate is shown.

Important Notes: Please ensure photos are of complete item, if a component please supply photo of both component and complete product, if zoomed in for a shot, please ensure overall shot is also supplied. In regard to a Quick hitch coupler failure, please also supply photos of the implements it is used with. Photo required of metre reading and serial plate of product.

Doherty Internal use only

Problem Code:	Warranty Approved
Warranty Confirmation Number <i>(ERP produced)</i>	

